

3

Einsatzgebiete

Bearbeitungs-, Bewegungs- und Positionieraufgaben mit mittleren Verfahrensgeschwindigkeiten. Horizontal und vertikal einsetzbar.

Konstruktionsvorteile

Schwingungsdämpfend – hohe Belastbarkeit.

Schlittenausführung

Grauguss EN-GJL-250 (Standardausführung), auf Anfrage Aluminium. Auf Wunsch Oberfläche chemisch vernickelt (Grauguss), harteloxiert (Aluminium). Auf Wunsch ab 100 mm geschabte teflonbeschichtete Führungsflächen.

Die Angaben über Gewicht und Belastungen gelten für Schlitten in Grauguss-Ausführung. Bei Aluminium-Schlitten verringern sich die Angaben um ca. 50%.

Kombinationen verschiedener Typen und Größen möglich.

Auf Anfrage Länge und Hub in Zwischengrößen lieferbar.

Wartung

Schwalbenschwanz-Führungen sollten entsprechend der Benutzung regelmäßig geschmiert werden. Bei Dauerbetrieb empfehlen wir den Anschluss an eine Zentralschmierung.

Zubehör

Umfangreiches Zubehör für alle Einsatzmöglichkeiten (siehe Zubehörprogramm).

Applications

Accurate positioning and movement in machining and inspection operations when no high speed are required. Suitable for horizontal and vertical operation.

Design advantages

High dampening effect on vibrations – slides have high-load carrying capacity.

Slide construction

Grey cast iron (EN-GJL-250), upon request in Aluminium. Upon request electroless nickel plating (grey cast iron), hard anodised (Aluminium).

Upon request slides with widths starting at 100 mm are available with a teflon-like coating on the ways to reduce friction.

The approximate weight and load capacity is for cast iron slides. For aluminium slides the approximate weight and load capacity will decrease by approx. 50%.

Various models and sizes may be compounded.

Other dimensions and travels are available upon request.

Maintenance

According to the usage of the slides a periodic lubrication is recommended. A central lubrication system is recommended for permanent usage.

Accessories

Many accessories are available for different applications (see accessories).

Schwalbenschwanz Schlittenführungen Dovetail Slides

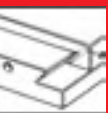

3

Schwalbenschwanz-Schlittenführungen
Dovetail slides

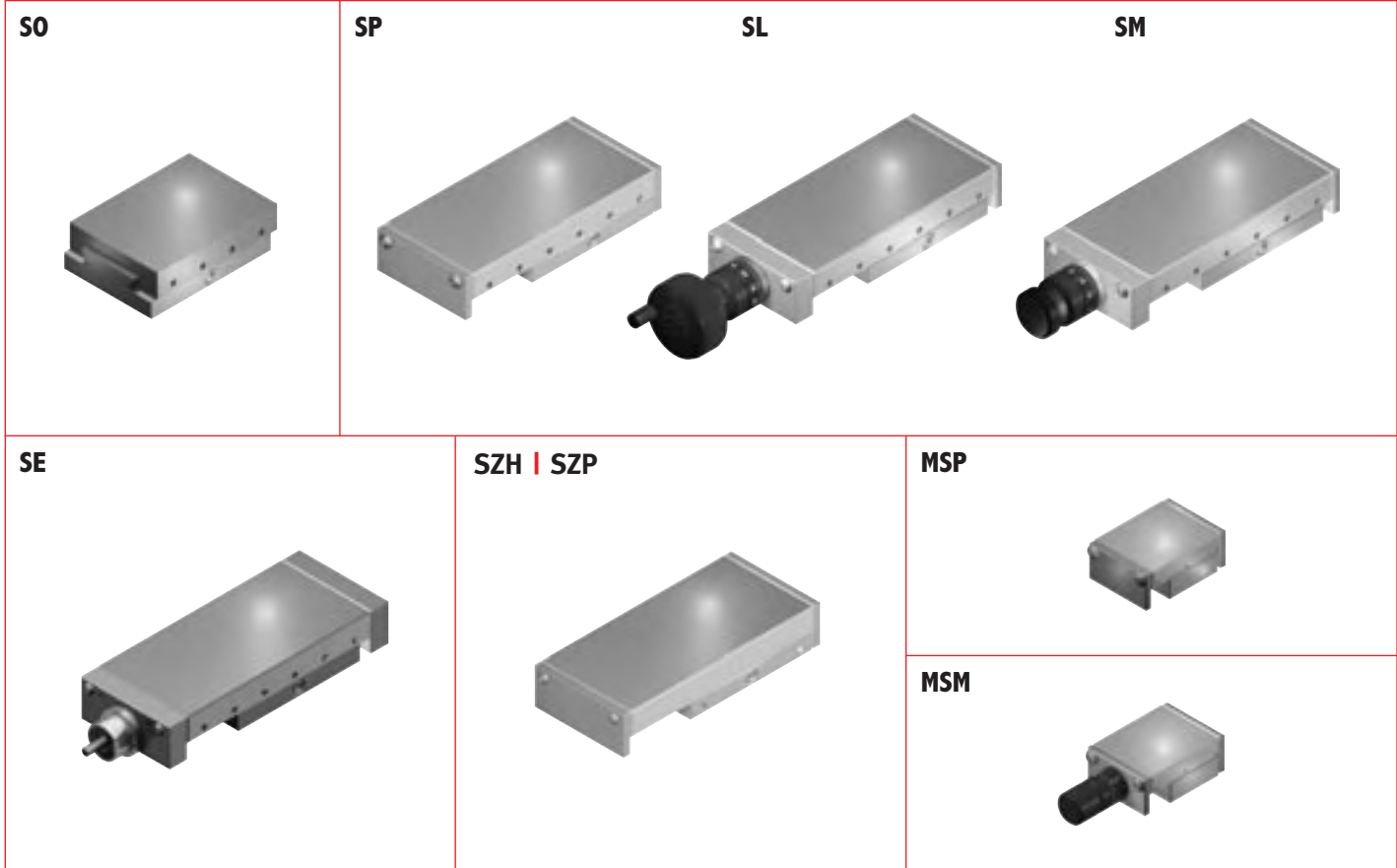

SO
offene Ausführung
open type

SP
Grundausführung, ohne Spindel, ohne Spindelmutter
plain without lead screw, without nut

SL
mit Handrad, Spindel und Spindelmutter
with hand-wheel, with lead screw, with nut

SM
mit Mikrometerrandel, Spindel und Spindelmutter
with knurled micrometer knob, with lead screw, with nut

SE
zum Anbau von Motoren
for motorized applications

SZH | SZP
mit eingebautem Zylinder
with built-in cylinder

MSP | MSM
Miniaturschlitten
miniature slides

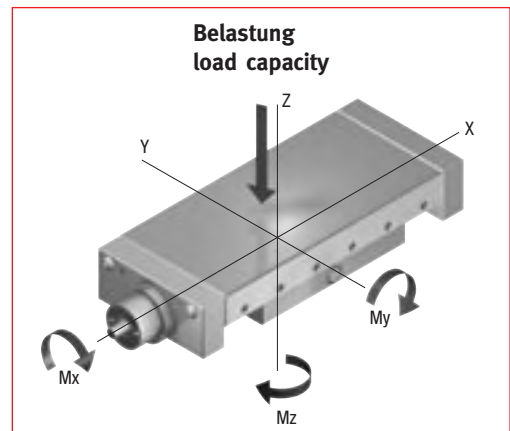

Die Belastungsangaben gelten bei ganzflächiger Belastung und ganzflächiger Schlittenbefestigung bei mittig stehendem Schlitten. Gültig für Einzelschlitten.

Indicated load capacities are based on full surface loading and full surface slide mounting with slide in centre position. All load indications apply to single slides.

SO
Langer Hub bei kurzer Schlittenlänge.
Standard Befestigungsbohrbild (siehe Zubehör).

SO
Extended travel at short slide length.
Standard mounting holes (see accessories).

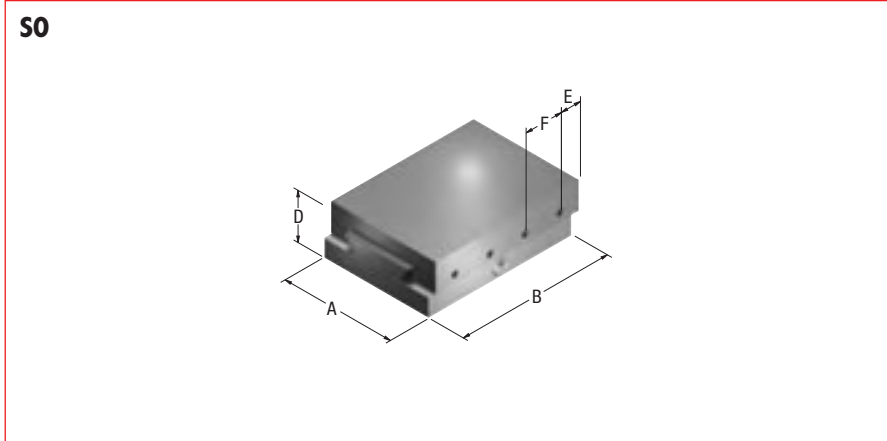

Größe Size	Hub Travel		Belastung Load capacity				Gewicht Weight SO kg	Belastung Load capacity SO N	Momente Torque SO Nm		
	A	B	C	D	E	F			Mx dyn	My dyn	Mz dyn
1	50	50	25	25	12,5	1 x 25	0,5	470	3,4	1,8	2,1
2	50	101	50	25	13,0	3 x 25	0,7	950	6,9	7,2	8,6
3	50	152	75	25	13,5	5 x 25	1,4	1430	10,0	16,0	19,0
4	50	202	100	25	13,5	7 x 25	1,8	1900	13,0	29,0	34,0
5	75	102	50	32	13,0	3 x 25	1,8	1410	14,0	9,2	11,0
6	75	152	75	32	13,5	5 x 25	2,9	2110	21,0	20,0	24,0
7	75	202	100	32	13,5	7 x 25	3,9	2800	28,0	36,0	43,0
8	75	252	125	32	13,5	9 x 25	4,8	3490	35,0	56,0	67,0
9	75	302	150	32	13,5	11 x 25	6,0	4190	42,0	81,0	96,0
10	100	102	50	37	13,5	3 x 25	3,4	1585	27,0	13,0	15,0
11	100	152	75	37	13,5	5 x 25	4,2	2360	40,0	29,0	35,0
12	100	203	100	37	14,0	7 x 25	5,9	3155	54,0	52,0	63,0
13	100	254	125	37	14,5	9 x 25	6,8	3940	67,0	82,0	98,0
14	100	305	150	37	15,0	11 x 25	8,8	4740	81,0	119,0	142,0
15	100	355	175	37	15,0	13 x 25	10,5	5515	94,0	161,0	192,0
16	100	405	200	37	15,0	15 x 25	11,8	6290	108,0	210,0	250,0
17	100	445	225	37	15,0	17 x 25	12,9	7070	121,0	265,0	315,0
18	100	505	250	37	15,0	19 x 25	14,0	7840	135,0	325,0	385,0
19	150	152	50	50	26,0	2 x 50	11,0	3070	77,0	30,0	36,0
20	150	152	75	50	26,0	2 x 50	11,0	3070	77,0	30,0	36,0
21	150	203	100	50	26,5	3 x 50	13,8	4100	103,0	54,0	65,0
22	150	253	125	50	26,5	4 x 50	15,0	5120	129,0	85,0	101,0
23	150	305	150	50	27,5	5 x 50	16,0	6170	155,0	123,0	147,0
24	150	406	200	50	28,0	7 x 50	22,0	8210	205,0	219,0	260,0
25	150	506	250	50	28,0	9 x 50	27,5	10240	255,0	340,0	405,0
26	150	606	300	50	28,0	11 x 50	32,5	12260	305,0	485,0	580,0
27	200	203	50	58	26,5	3 x 50	23,0	5790	184,0	73,0	87,0
28	200	203	100	58	26,5	3 x 50	23,0	5790	184,0	73,0	87,0
29	200	304	150	58	27,0	5 x 50	26,1	8680	275,0	164,0	195,0
30	200	406	200	58	28,0	7 x 50	34,4	11590	365,0	290,0	345,0
31	200	510	250	58	30,0	9 x 50	43,0	14560	460,0	460,0	550,0
32	200	610	300	58	30,0	11 x 50	51,5	17420	550,0	660,0	785,0
33	200	710	350	58	30,0	13 x 50	60,0	20270	645,0	895,0	1065,0
34	200	810	400	58	30,0	15 x 50	67,0	23100	735,0	1165,0	1385,0
35	200	810	500	58	30,0	15 x 50	67,0	23100	735,0	1165,0	1385,0
36	200	810	600	58	30,0	15 x 50	67,0	23100	735,0	1165,0	1385,0

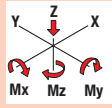

SP

Schlitten (Grundauführung) ohne Spindel und ohne Spindelmutter.

SL

Schlitten mit Handrad, Spindel und Spindelmutter.

SM

Schlitten mit Mikrometerrandel, Spindel und Spindelmutter.

SCP | SCL | SCM

Feststehender Kreuzschlitten. Mittig verbohrt (Standardausführung).

Bei außermittiger Montage bitte Maß V und W angeben.

SCSP | SCSL | SCSM

Kreuzschlitten mit Drehteller. Mittig verbohrt (Standardausführung).

Bei außermittiger Montage bitte Maß V und W angeben.

Metrische Standardspindeln gehärtet und geschliffen. Steigungsgenauigkeit +/- 0,02 mm je 300 mm Hub. Sonderspindeln auf Anfrage.

Standard Befestigungsbohrbild (siehe Zubehör).

SP

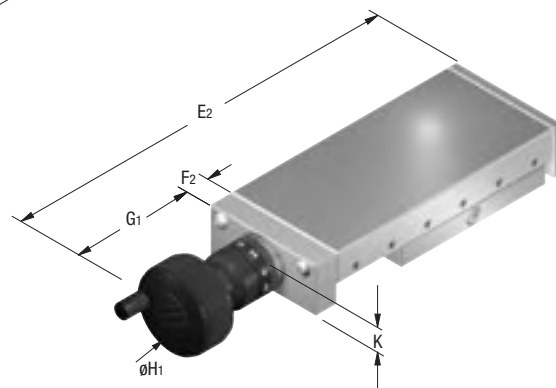
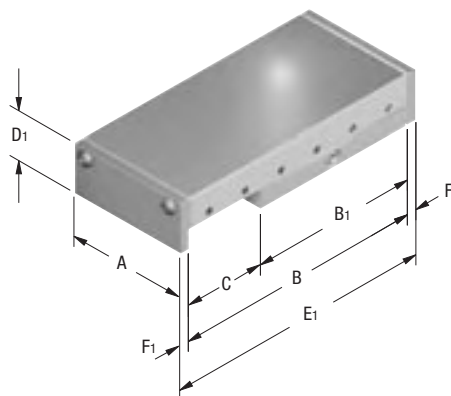

SL

SP

Standard (plain) without lead screw, without nut.

SL

with hand-wheel, with lead screw, with nut.

SM

with knurled micrometer knob, with lead screw, with nut.

SCP | SCL | SCM

fixed compound XY-slide. Centre-mounting (standard). Please advise dimensions V and W when off-centre mounting is required.

SCSP | SCSL | SCSM

compound XY-slide with swivel plate. Centre-mounting (standard).

Please advise dimensions V and W when off-centre mounting is required.

Metric standard lead screws are hardened and ground. Pitch accuracy is +/- 0,02 mm per 300 mm of travel. Higher accuracy lead screws are available upon request.

Standard mounting holes (see accessories).

Größe Size	Hub Travel											ohne Balg without bellows	
	A	B	B ₁	C	D ₁	D ₂	D ₃	E ₁	E ₂	E ₃	F ₁	F ₂	
1	50	76	50	22	25	50	-	88	156	138	6	14	
2	50	102	76	25	25	50	-	114	182	164	6	14	
3	50	152	101	50	25	50	-	164	232	214	6	14	
4	75	102	76	25	32	64	82	114	193	170	6	15	
5	75	127	101	25	32	64	82	139	218	195	6	15	
6	75	152	101	50	32	64	82	164	243	220	6	15	
7	100	152	126	25	37	74	92	164	243	222	6	15	
8	100	203	152	50	37	74	92	215	294	273	6	15	
9	100	254	203	50	37	74	92	266	345	324	6	15	
10	100	305	228	75	37	74	92	317	396	375	6	15	
11	150	203	152	50	50	100	120	219	334	297	8	16	
12	150	305	203	100	50	100	120	321	436	399	8	16	
13	150	406	304	100	50	100	120	422	537	500	8	16	
14	150	406	253	150	50	100	120	422	537	500	8	16	
15	200	457	304	150	58	116	136	473	588	551	8	16	
16	200	610	406	200	58	116	136	626	741	704	8	16	
17	300	410	308	100	75	150	180	430	607	538	10	20	
18	300	610	408	200	75	150	180	630	807	738	10	20	
19	300	710	408	300	75	150	180	730	907	838	10	20	
20	300	910	508	400	75	150	180	930	1107	1038	10	20	
21	300	1010	508	500	75	150	180	1030	1207	1138	10	20	
22	300	1210	608	600	75	150	180	1230	1407	1338	10	20	
23	400	610	408	200	102	204	244	650	868	783	20	30	
24	400	710	408	300	102	204	244	750	968	883	20	30	
25	400	810	408	400	102	204	244	850	1068	983	20	30	
26	400	910	508	400	102	204	244	950	1168	1083	20	30	
27	400	1010	508	500	102	204	244	1050	1268	1183	20	30	
28	400	1110	508	600	102	204	244	1150	1368	1283	20	30	
29	400	1210	608	600	102	204	244	1250	1468	1383	20	30	

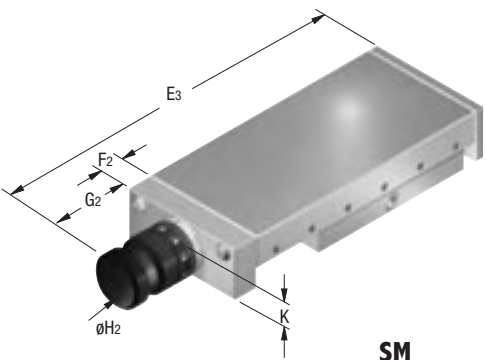

SM

SCP

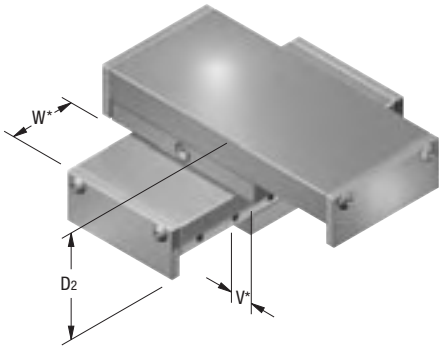

SCL

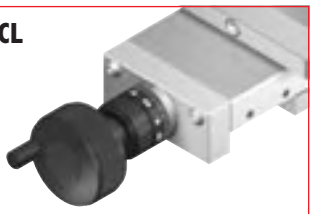

SCM

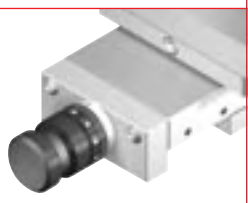

SCSP

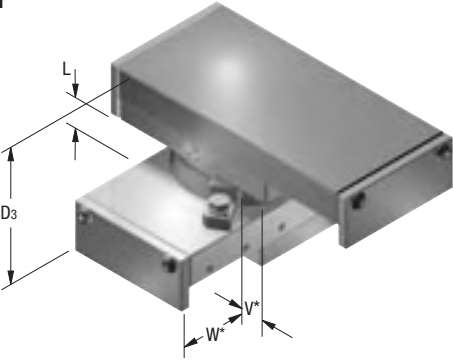

SCSL

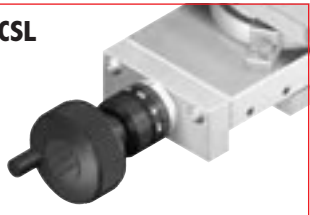

SCSM

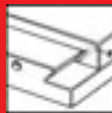

3

mit Balg with bellows						Spindel Ø x Steigung Lead screw Ø x pitch			Gewicht Weight SP	Belastung Load capacity SP SL SM	Momente Torque SP SL SM			
F1	F2	G1	G2	H1	H2ø		K	L	kg	N	Nm	Mx dyn	My dyn	Mz dyn
14	14	60,0	42,0	50	23,9	M 6 x 1	12,5	-	0,6	470	3,4	1,8	2,1	
14	14	60,0	42,0	50	23,9	M 6 x 1	12,5	-	0,8	715	5,2	4,1	4,9	
14	14	60,0	42,0	50	23,9	M 6 x 1	12,5	-	1,1	950	6,9	7,2	8,6	
15	15	70,0	47,0	56	31,0	M 8 x 1	16,0	18	1,8	1055	10,0	5,1	6,1	
15	15	70,0	47,0	56	31,0	M 8 x 1	16,0	18	2,0	1400	14,0	9,1	10,0	
15	15	70,0	47,0	56	31,0	M 8 x 1	16,0	18	2,5	1400	14,0	9,1	10,0	
15	15	70,0	49,0	56	35,0	M 12 x 1	18,0	18	4,0	1950	33,0	20,0	24,0	
15	15	70,0	49,0	56	35,0	M 12 x 1	18,0	18	4,7	2360	40,0	29,0	35,0	
15	15	70,0	49,0	56	35,0	M 12 x 1	18,0	18	6,1	3150	54,0	52,0	63,0	
15	15	70,0	49,0	56	35,0	M 12 x 1	18,0	18	7,0	3540	61,0	66,0	79,0	
16	16	107,0	70,0	106	48,0	M 20 x 1	24,3	20	10,0	3075	77,0	30,0	36,0	
16	16	107,0	70,0	106	48,0	M 20 x 1	24,3	20	13,2	4100	103,0	54,0	65,0	
16	16	107,0	70,0	106	48,0	M 20 x 1	24,3	20	18,0	6150	155,0	123,0	146,0	
16	16	107,0	70,0	106	48,0	M 20 x 1	24,3	20	16,5	5120	129,0	85,0	101,0	
16	16	107,0	70,0	106	48,0	M 20 x 1	28,3	20	30,0	8680	275,0	164,0	195,0	
16	16	107,0	70,0	106	48,0	M 20 x 1	28,3	20	40,0	11595	365,0	290,0	345,0	
70	70	166,5	97,5	125*	68,0	Tr. 26 x 4	35,0	30	59,0	11350	605,0	235,0	280,0	
70	70	166,5	97,5	125*	68,0	Tr. 26 x 4	35,0	30	80,0	15040	800,0	410,0	490,0	
70	70	166,5	97,5	125*	68,0	Tr. 26 x 4	35,0	30	92,0	15040	800,0	410,0	490,0	
70	70	166,5	97,5	125*	68,0	Tr. 26 x 4	35,0	30	110,0	18725	1000,0	640,0	760,0	
90	90	166,5	97,5	125*	68,0	Tr. 26 x 4	35,0	30	125,0	18725	1000,0	640,0	760,0	
100	100	166,5	97,5	125*	68,0	Tr. 26 x 4	35,0	30	145,0	22410	1195,0	915,0	1095,0	
70	70	208,0	123,0	200*	84,0	Tr. 32 x 4	43,5	40	169,0	23275	1360,0	470,0	560,0	
70	70	208,0	123,0	200*	84,0	Tr. 32 x 4	43,5	40	182,0	23275	1360,0	470,0	560,0	
90	90	208,0	123,0	200*	84,0	Tr. 32 x 4	43,5	40	195,0	23275	1360,0	470,0	560,0	
90	90	208,0	123,0	200*	84,0	Tr. 32 x 4	43,5	40	225,0	28980	1695,0	730,0	870,0	
100	100	208,0	123,0	200*	84,0	Tr. 32 x 4	43,5	40	238,0	28980	1685,0	730,0	870,0	
100	100	208,0	123,0	200*	84,0	Tr. 32 x 4	43,5	40	251,0	28980	1695,0	730,0	870,0	
100	100	208,0	123,0	200*	84,0	Tr. 32 x 4	43,5	40	270,0	34680	2025,0	1050,0	1250,0	

Schwalbenschwanz-Schlittenführungen
Dovetail slides

SE

Lieferbar je nach Einsatz
 Montageart **N** = normal montiert
 Montageart **U** = umgekehrt montiert.

Spindelausführung

Präzisions-Rollenspindeln (Standardausführung).
 Hohe Belastung. Drehzahl bis 3000 1/min. Hohe Steifigkeit. Lange Lebensdauer.
 Steigungsgenauigkeit +/- 0,015 mm je 300 mm Hub. Verfahrensgeschwindigkeit je nach Spindelsteigung und Antrieb max. 20 m/min. Positioniergenauigkeit je nach Spindelausführung und Rückmeldesystem max. 0,001 mm.

Auf Wunsch Kugelgewindespindeln. Mittlere Belastung. Hoher Wirkungsgrad.
 Drehzahl bis 2000 1/min. Steigungsgenauigkeit +/- 0,015 mm/ 300 mm Hub.
 Andere Gewindesteigungen und Steigungsgenauigkeiten auf Anfrage.

Antriebsmöglichkeiten

Schritt-, Servo- oder Gleichstrommotoren.
 Motoradapter nach Kundenwunsch.

Standard Befestigungsbohrbild (siehe Zubehör).

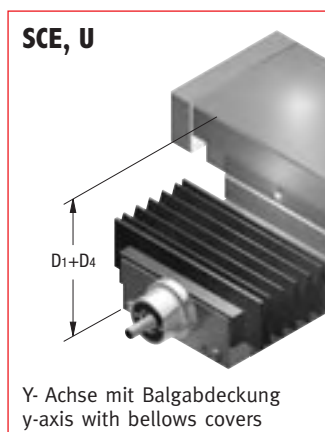
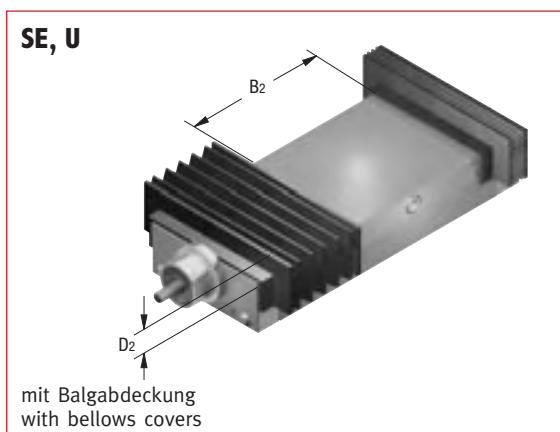
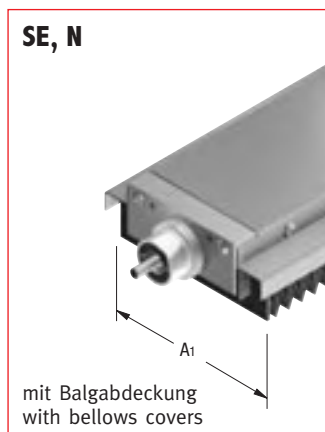
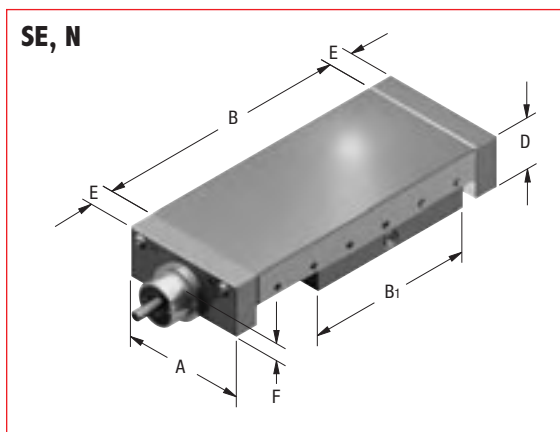

SE

For different applications
 in normal mounting **N**
 or inverse mounting **U**.

Spindle design

Planetary roller screw (standard) with high-load capacity, Speeds up to 3000 RPM. High rigidity and long-life. Pitch accuracy is +/- 0,015 mm per 300 mm travel. Travel speed depending on lead screw pitch and drive max. 20 m/min. Positioning accuracy of max. 0,001 mm is available depending on the lead screw and positioning feedback system used.
 Upon request precision ball screws with medium-load capacity, high efficiency. Speeds up to 2000 RPM. Pitch accuracy is +/- 0,015 mm per 300 mm travel.
 Lead screws with other pitch and higher accuracy lead screws are available upon request.

Means of drive

Stepper-, Servo- or AC-motors. Motor flanges and couplings are available upon request.

Standard mounting holes (see accessories).

Größe Size	Hub Travel					Montageart N Mounting type N					D ₂₌₁
	A	A ₁	B	B ₁	B ₂	C	D	D ₁	D _{1+D₃}	D ₃	
4	75	110	102	76	50	25	32	64	79	15	14
5	75	110	127	101	65	25	32	64	79	15	14
6	75	110	152	101	55	50	32	64	79	15	14
7	100	135	152	126	100	25	37	74	89	15	14
8	100	135	203	152	115	50	37	74	89	15	14
9	100	135	254	203	160	50	37	74	89	15	14
10	100	135	305	228	180	75	37	74	89	15	14
11	150	205	203	152	120	50	50	100	125	25	24
12	150	205	305	203	150	100	50	100	125	25	24
13	150	205	406	304	250	100	50	100	125	25	24
14	150	205	406	253	190	150	50	100	125	25	24
15	200	255	457	304	250	150	58	116	141	25	24
16	200	255	610	406	340	200	58	116	141	25	24
17	300	375	410	308	280	100	75	150	185	35	32
18	300	375	610	408	380	200	75	150	150	-	32
19	300	375	710	408	380	300	75	150	150	-	32
20	300	375	910	508	480	400	75	150	150	-	32
21	300	375	1010	508	480	500	75	150	150	-	32
22	300	375	1210	608	580	600	75	150	150	-	32
23	400	480	610	408	380	200	102	204	229	25	37
24	400	480	710	408	380	300	102	204	229	25	37
25	400	480	810	408	380	400	102	204	229	25	37
26	400	480	910	508	480	400	102	204	229	25	37
27	400	480	1010	508	480	500	102	204	204	-	37
28	400	480	1110	508	480	600	102	204	204	-	37
29	400	480	1210	608	580	600	102	204	204	-	37

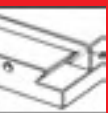

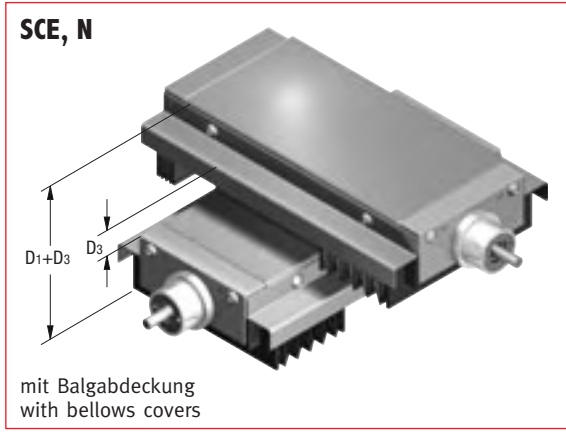
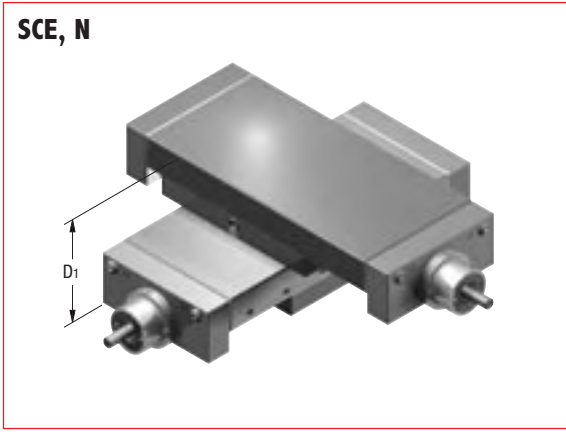
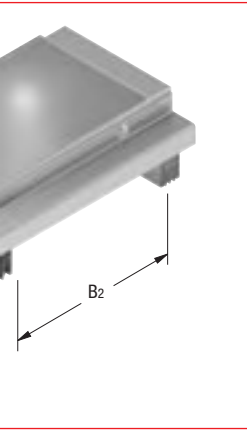

mit Balgabdeckung
with bellows covers

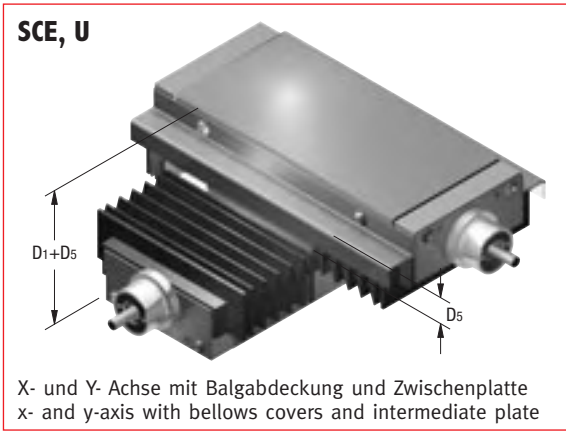
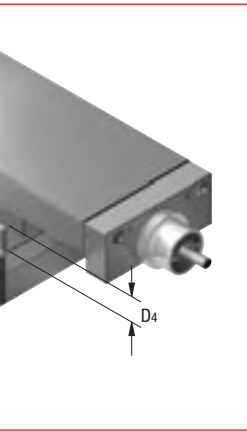

X- und Y- Achse mit Balgabdeckung und Zwischenplatte
x- and y-axis with bellows covers and intermediate plate

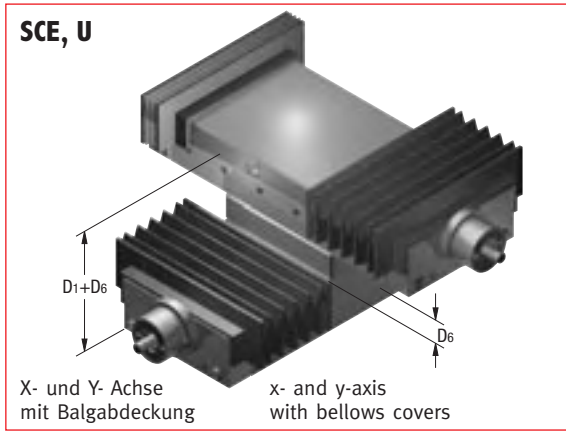

X- und Y- Achse mit Balgabdeckung
x- and y-axis with bellows covers



3

Montageart U Mounting type U						ohne Balg without bellows	mit Balg with bellows		Rollenspindel Ø x Steigung Planetary roller screw Ø x pitch	Kugelgewindespindel Ø x Steigung Ball screw Ø x pitch	Gewicht Weight	Belastung Load capacity	Momente Torque		
D1+D4	D4	D1+D5	D5	D1+D6	D6	E	E	F			SE kg	SE N	SE Nm	My dyn	Mz dyn
79	15	94	30	79	15	15	15	11,5	8 x 1 / 8 x 2	-	1,8	1055	10,0	5,1	6,1
79	15	94	30	79	15	15	15	11,5	8 x 1 / 8 x 2	-	2,0	1400	14,0	9,1	10,0
79	15	94	30	79	15	15	15	11,5	8 x 1 / 8 x 2	-	2,5	1400	14,0	9,1	10,0
89	15	104	30	89	15	15	15	13,5	8 x 1 / 8 x 2	-	4,0	1950	33,0	20,0	24,0
89	15	104	30	89	15	15	15	13,5	8 x 1 / 8 x 2	-	4,7	2360	40,0	29,0	35,0
84	10	94	20	89	15	15	15	13,5	8 x 1 / 8 x 2	-	6,1	3150	54,0	52,0	63,0
84	10	94	20	89	15	15	15	13,5	8 x 1 / 8 x 2	-	7,0	3540	61,0	66,0	79,0
125	25	150	50	125	25	16	16	19,0	15 x 2 / 15 x 4	20 x 4	10,0	3075	77,0	30,0	36,0
100	-	125	50	125	25	16	16	19,0	15 x 2 / 15 x 4	20 x 4	13,2	4100	103,0	54,0	65,0
100	-	125	25	125	25	16	16	19,0	15 x 2 / 15 x 4	20 x 4	18,0	6150	155,0	123,0	146,0
100	-	125	25	125	25	16	16	19,0	15 x 2 / 15 x 4	20 x 4	16,5	5120	129,0	85,0	101,0
116	-	131	15	141	25	16	16	21,5	15 x 2 / 15 x 4	20 x 4	30,0	8680	275,0	164,0	195,0
116	-	131	15	141	25	16	16	21,5	15 x 2 / 15 x 4	20 x 4	40,0	11595	365,0	290,0	345,0
185	35	220	70	185	35	20	70	26,0	23 x 4	25 x 4	59,0	11350	605,0	235,0	280,0
150	-	185	35	150	-	20	70	26,0	23 x 4	25 x 4	80,0	15040	800,0	410,0	490,0
150	-	185	35	150	-	20	70	26,0	23 x 4	25 x 4	92,0	15040	800,0	410,0	490,0
150	-	150	-	150	-	20	70	26,0	23 x 4	25 x 4	110,0	18725	1000,0	640,0	760,0
150	-	150	-	150	-	20	90	26,0	23 x 4	25 x 4	125,0	18725	1000,0	640,0	760,0
150	-	150	-	150	-	20	100	26,0	23 x 4	-	145,0	22410	1195,0	915,0	1095,0
244	40	284	80	229	25	70	70	34,0	30 x 4	-	169,0	23275	1360,0	470,0	560,0
244	40	284	80	229	25	0	70	34,0	30 x 4	-	182,0	23275	1360,0	470,0	560,0
244	40	284	80	229	25	90	90	34,0	30 x 4	-	195,0	23275	1360,0	470,0	560,0
204	-	244	40	229	25	90	90	34,0	30 x 4	-	225,0	28980	1695,0	730,0	870,0
204	-	244	40	204	-	100	100	34,0	30 x 4	-	238,0	28980	1685,0	730,0	870,0
204	-	244	40	204	-	100	100	34,0	30 x 4	-	251,0	28980	1695,0	730,0	870,0
204	-	204	-	204	-	100	100	34,0	30 x 4	-	270,0	34680	2025,0	1050,0	1250,0

SZH | SZP mit eingebautem Zylinder with built-in cylinder

SZH | SZP

Platzsparend durch eingebauten Zylinder.

Antrieb

Wahlweise für Hydraulik (Typ SZH) oder Pneumatik (Type SZP).

SZH | SZP

Compact design with built-in cylinder for limited space constructions.

Drive

Either for hydraulic (Type SZH) or pneumatic (SZP).

SZH | SZP

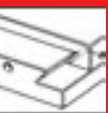
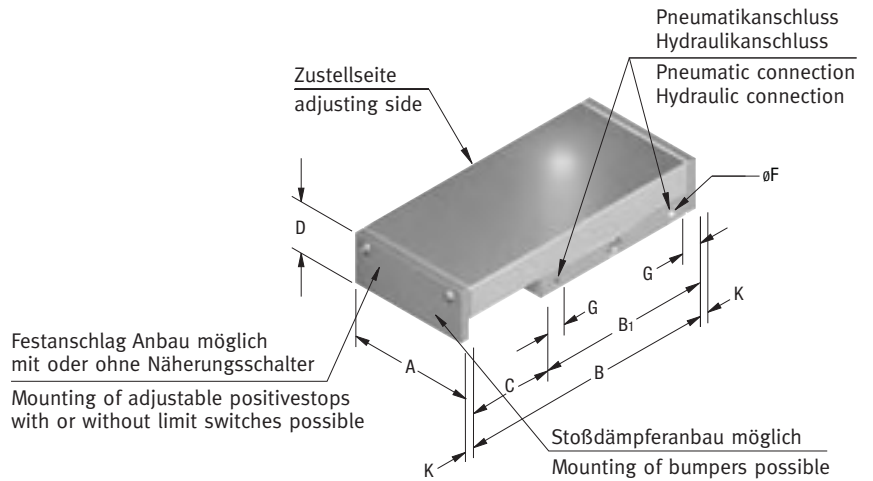

3

Größe Size	Hub Travel			Anschlussgewinde Thread size		Gewicht Weight SZH SZP			Belastung Load capacity SZH SZP		Momente Torque SZH SZP Nm		
	A	B	B ₁	C	D	F	G	K	kg	N	Mx dyn	My dyn	Mz dyn
7	100	152	126	25	50	R 1/4"	34	15	5,2	1950	33,0	20,0	24,0
8	100	203	152	50	50	R 1/4"	34	15	6,5	2360	40,0	29,0	35,0
9	100	254	203	50	50	R 1/4"	34	15	8,0	3150	54,0	52,0	63,0
10	100	305	228	75	50	R 1/4"	34	15	8,8	3540	61,0	66,0	79,0
11	150	203	152	50	50	R 1/4"	34	16	10,0	3075	77,0	30,0	36,0
12	150	305	203	100	50	R 1/4"	34	16	13,2	4100	103,0	54,0	65,0
13	150	406	304	100	50	R 1/4"	34	16	18,0	6150	155,0	123,0	146,0
14	150	406	253	150	50	R 1/4"	34	16	16,5	5120	129,0	85,0	101,0
15	200	457	304	150	58	R 1/4"	34	16	30,0	8680	275,0	164,0	195,0
16	200	610	406	200	58	R 1/4"	34	16	40,0	11595	365,0	290,0	345,0

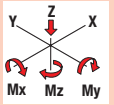

Schwalbenschwanz-Schlittenführungen Dovetail Slides

Beispiele für Befestigungsbohrungen

Bohrungen zur Befestigung der Schlittenführung nach Angaben bzw. Zeichnung auf Kundenwunsch.

Examples for mounting holes

Upon request Mounting holes are available according to customer's drawing.

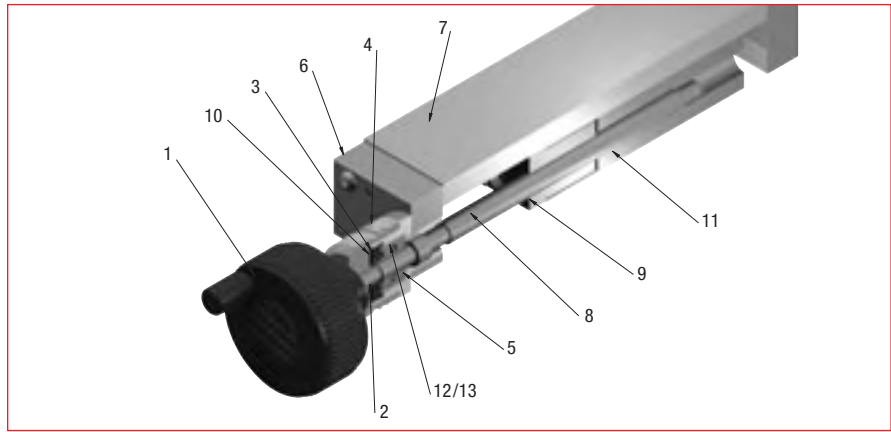

Schnitt durch Schlittenführung mit Spindel und Spindelmutter		Sectional view of the slide with spindle and spindle nut	
1	Handrad		Hand-wheel
2	Druckring	Größe 1-22	Pressure ring size 1-22
3	Spannring	Größe 1-22	Locking ring size 1-22
4	Skala		Graduated dial
5	Spindellagergehäuse	Größe 1-22	Duplex bearing size 1-22
6	Endplatte		End plate
7	Schlittenführung	Außenteil	Slide saddle
8	Spindel		Lead screw
9	Spindelmutter		Nut
10	Spannring	Größe 23-29	Locking ring size 23-29
11	Schlittenführung	Innenteil	Slide base
12	gepaartes Spindellager		Spindle bearing
13	Axial-Schräggugellagereinheit	Größe 23-29	Angular ball bearing unit size 23-29

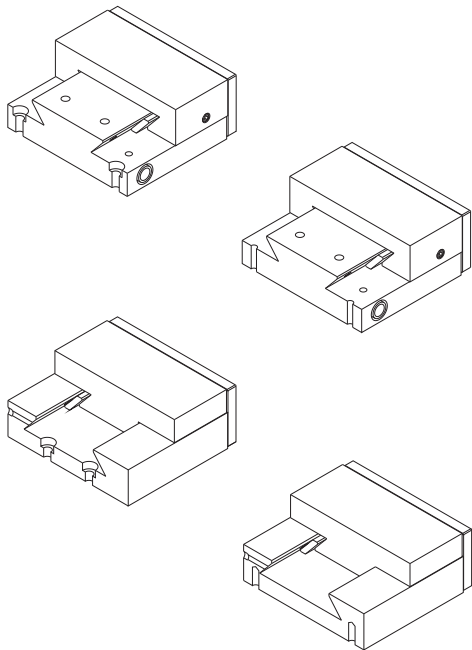

SZH | SZP

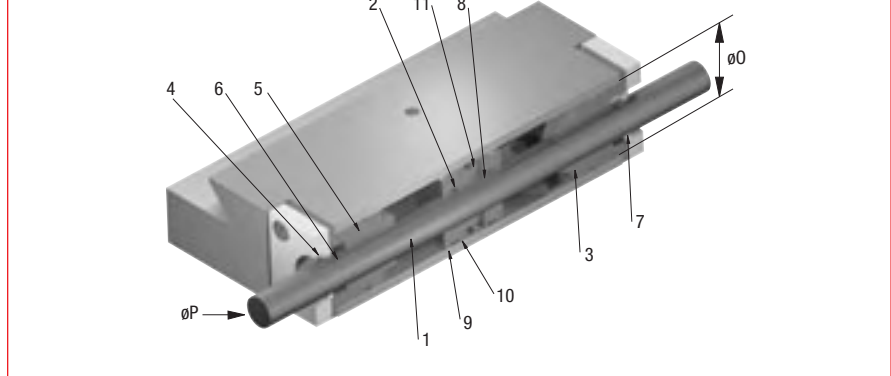

Zylinderbausatz SZH SZP		Built-in Cylinder SZH SZP	
1	Kolbenstange	Ø P = 12 mm	Piston rod Ø P = 12 mm
2	Kolben	Ø O = 30 mm	Piston Ø O = 30 mm
3	Führungsbuchse		Guide bushing
4	Zylinderkopf		Cylinder head
5	O-Ring		O-ring
6	Dichtung – Kolbenstange		Rod packing
7	Abstreifer		Wiper
8	O-Ring		O-ring
9	Führungsband		Piston guide ring
10	Kolbendichtung		Piston packing
11	Zylinderstift		Cylinder pin

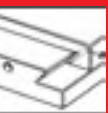

3